

# KUKA | Xpert

Identification number: AR7159

货号	0000-153-429
材料状态	10 - 批准预生产
制造商	KUKA Roboter
产品图片	

# Spare parts

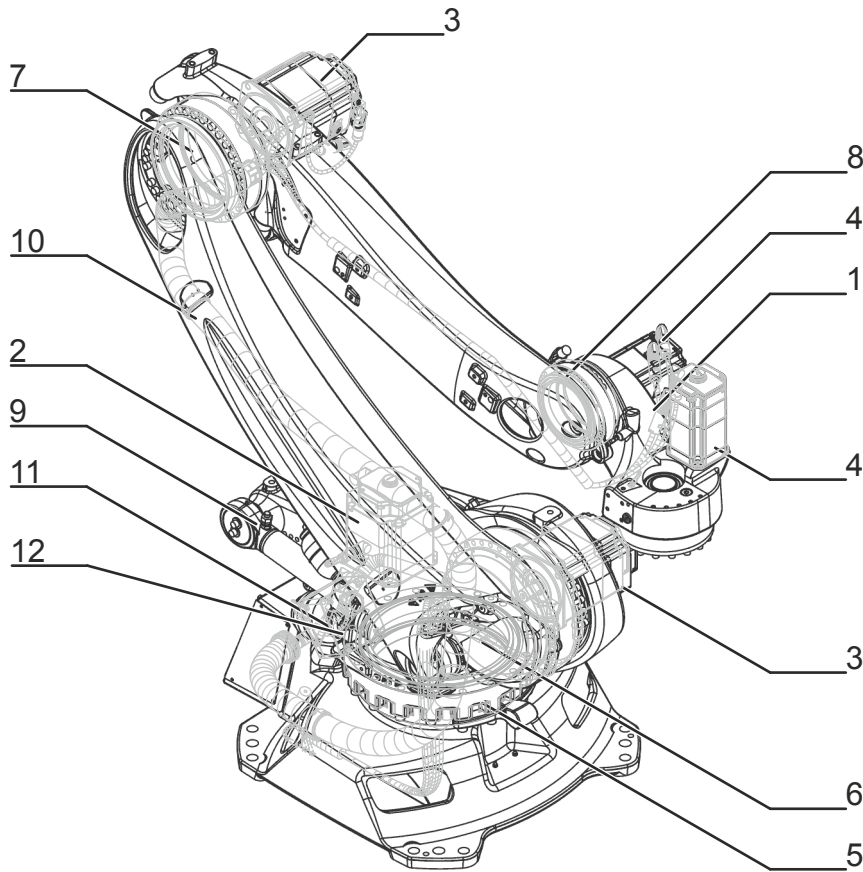

Spare parts graphic KR 240 R3200 PA arctic , schematic representation

Pos.	Article number	Designation	Component	Work instruction
1	0000-245-225	SPP wrist Quantec PA arctic	Wrist	
2	0000-192-295	SPP AC servomotor I2/1FK7101	Motor A1	Exchanging motor A1
3	0000-192-293	SPP AC servomotor K2/1FK7103	Motor A2 Motor A3	Exchanging motor A2 Exchanging motor A3
4	0000-192-297	SPP AC servomotor D01/1FK7063	Motor A5 Motor A6	Exchanging motor A5 Exchanging motor A6
5	0000-245-245	SPP Gearbox RV-700CS i=256,85 arc,no oil	Gear A1	
6	0000-245-246	SPP Gearbox RV-700N i=267,43 arc, no oil	Gear A2	

Pos.	Article number	Designation	Component	Work instruction
7	0000-245-253	SPP Gearbox RV-500N I=252,33 arc, no oil	Gear A3	
8	0000-245-237	SPP Gearbox RV-160N i=156 arctic, no oil	Gear A5	
9	0000-245-232	SPP counterbalancer heavy arctic	Counterbalancing system	
10	0000-237-970	KRC4 roboter cable set Quantec PA arctic	Cable set	
11	0000-236-268	Resolver Digital Converter RDC Cool	RDC	
12	0000-236-267	Electronic Data Storage EDS Cool	EDS	

Export to Excel 

# Maintenance information

## Gear oil



The quantity of oil drained depends on the draining time and the oil temperature. The refilling quantity is the quantity of oil that was drained from the gear unit at the correct operating temperature and with the correct draining time. This oil quantity must be determined. Only this quantity of oil may be used when refilling.

If less than 70 % of the specified oil quantity flows out, flush the gear unit with the determined quantity of drained oil once, then pour in the amount of oil that was drained. If less than 50% of the specified oil quantity flows out (e.g. inclined installation), the flushing operation must be repeated twice. During the flushing procedure, move the axis at jog velocity throughout the entire axis range.

The oil quantities specified in the table correspond to the oil quantities in the gear unit at first filling.

Gear oil new filling quantity	
A1	6.50 l
A2	2.90 l
A3	1.80 l
A4	-
A5	0.80 l
A6	1.20 l
Gear oil refilling quantity	
A1	5.20 l
A2	2.50 l
A3	1.70 l
A4	-
A5	0.70 l
A6	1.00 l

# Counterbalancing system

<b>Gas pressure p0</b>	156 bar
<b>Oil pressure p1</b>	176 bar

# 技术数据

## 基本数据

	KR 240 R3200 PA arctic
轴数	5
可控制的轴数	4
工作空间体积	77.9 m <sup>3</sup>
位姿重复精度 (ISO 9283)	± 0.06 mm
重量	约 1103 kg
额定负荷	240 kg
最大负载能力	-
最大运动范围	3195 mm
防护等级 (IEC 60529)	IP65
机器人腕部防护等级 (IEC 60529)	IP65
噪声等级	< 75 dB (A)
安装位置	地面
占地面积	830 mm x 830 mm
运动系统安装面布孔图	S934
允许倾角	≤ 5 °
标准色	底座： 黑色 (RAL 9005); 活动部件： 库卡橙色 2567
控制系统	KR C4
变压器名称	KR C4: KR240R3200PA C4 FLR

# 环境条件

湿度等级 (EN 60204)	-
环境条件分类 (EN 60721-3-3)	3K3
环境温度	
运行时	-30 °C 至 10 °C (243 K 至 283 K)
仓储和运输时	-40 °C 至 60 °C (233 K 至 333 K)

# 轴数据

运动范围	
A1	±185 °
A2	-140 ° / -5 °
A3	0 ° / 155 °
A4	-
A5	-
A6	±350 °
额定负载时的速度	
A1	105 °/s
A2	101 °/s
A3	107 °/s
A4	-
A5	173 °/s
A6	242 °/s

# 工作区域

Dimensions: mm

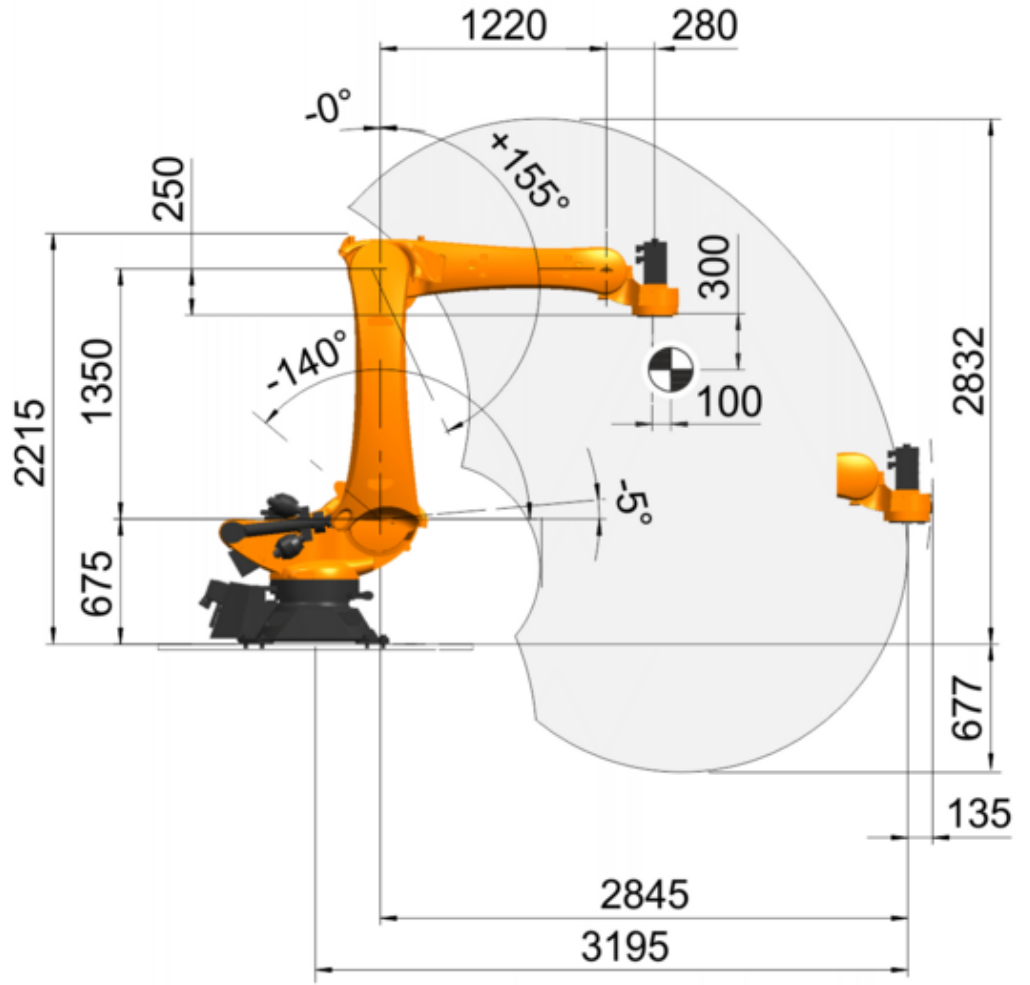





KR 240 R3200 PA 工作区域

# 负载能力

额定负荷	240 kg
最大负载能力	-
法兰 <b>lx</b> 额定质量转动惯量	120 kgm <sup>2</sup>
法兰 <b>ly</b> 额定质量转动惯量	120 kgm <sup>2</sup>
法兰 <b>lz</b> 额定质量转动惯量	120 kgm <sup>2</sup>
底座的额定附加负载	-
底座的最大附加负载	-
转盘的额定附加负载	0 kg
旋转机构的最大附加负载	300 kg
大臂的额定附加负载	0 kg
大臂的最大附加负载	130 kg
小臂的额定附加负载	50 kg
小臂的最大附加负载	150 kg
负载重心额定距离	
<b>Lxy</b>	100 mm
<b>Lz</b>	300 mm

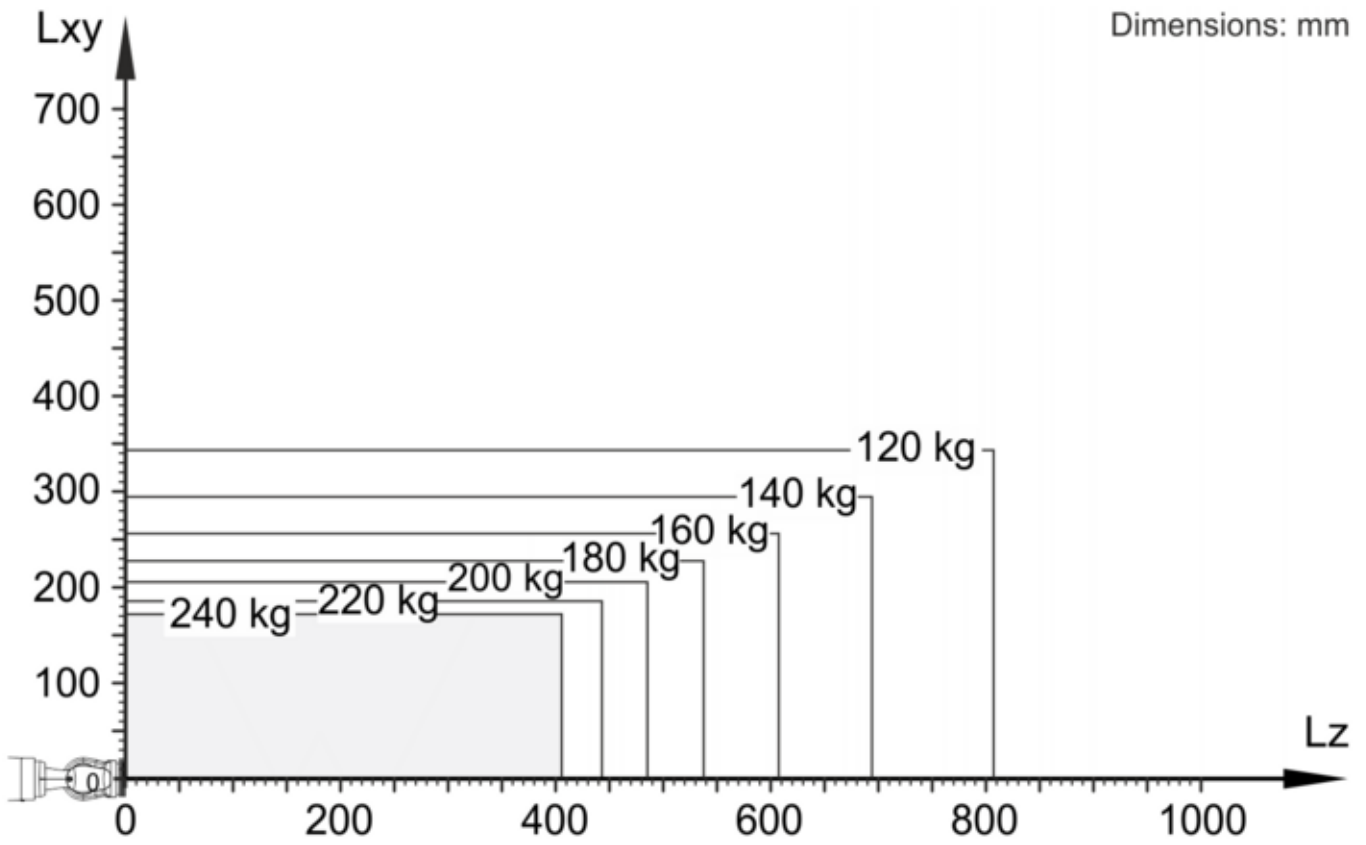

KR QUANTEC PA 负载能力图表，负载能力 240 kg

# 连接法兰

机器人腕部类型	180/240 kg
连接法兰	见图纸

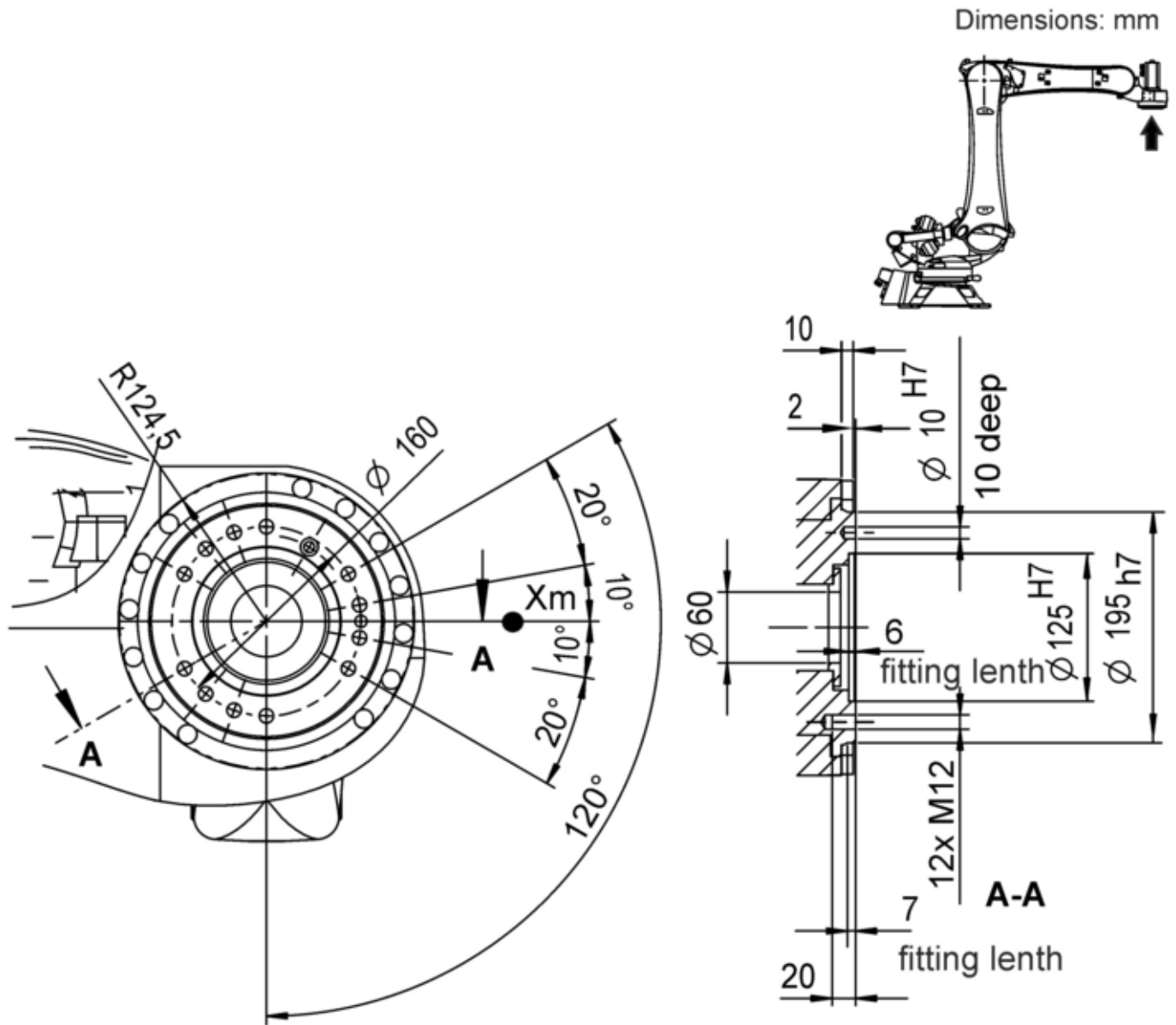

连接法兰，适配器

# 地基负载

纵向动力 <b>F(v)</b>	
<b>F(v 正常)</b>	19100 N
<b>F(vmax)</b>	24000 N
横向动力 <b>F(h)</b>	
<b>F(h 正常)</b>	9200 N
<b>F(hmax)</b>	16000 N
倾覆力矩 <b>M(k)</b>	
<b>M(k 正常)</b>	24000 Nm
<b>M(kmax)</b>	49000 Nm
轴 2 转矩 <b>M(r)</b>	
<b>M(r 正常)</b>	10200 Nm
<b>M(rmax)</b>	35000 Nm

垂直力  $F(v)$ 、水平力  $F(h)$ 、倾斜力矩  $M(k)$ 、轴 1 的转矩  $M(r)$

# Flange loads

## Flange loads

Due to the motion of the payload (e.g. tool) mounted on the robot, forces and torques act on the mounting flange. These forces and torques depend on the motion profile as well as the mass, load center of gravity and mass moment of inertia of the payload.

The specified values refer to nominal payloads at the nominal distance and do not include safety factors. It is imperative for the load data to be entered in the robot controller. The robot controller takes the payload into consideration during path planning. A reduced payload does not necessarily result in lower forces and torques.

The values are guide values determined by means of trial and simulation and refer to the most heavily loaded machine in the robot family. The actual forces and torques may differ due to internal and external influences on the mounting flange or a different point of application. It is therefore advisable to determine the exact forces and torques where necessary on site under the real conditions of the actual robot application.

The operating values may occur permanently in the normal motion profile. It is advisable to rate the tool for its fatigue strength.

The EMERGENCY STOP values may arise in the event of an Emergency Stop situation of the robot. As these should only occur very rarely during the service life of the robot, a static strength verification is usually sufficient.

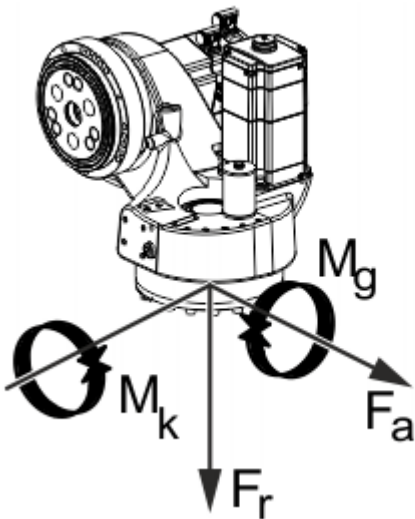

Flange loads

Flange loads during operation	
<b>F(a)</b>	4100 N
<b>F(r)</b>	4100 N

<b>M(k)</b>	1500 Nm
<b>M(g)</b>	1660 Nm
<b>Flange loads in the case of EMERGENCY STOP</b>	
<b>F(a)</b>	5400 N
<b>F(r)</b>	6100 N
<b>M(k)</b>	3550 Nm
<b>M(g)</b>	4350 Nm

Axial force  $F(a)$ , radial force  $F(r)$ , tilting torque  $M(k)$ , torque about mounting flange  $M(g)$

# Dangerous goods information

The following parts of the product must be considered dangerous goods with regard to their transportation in public spaces:

Pos.	Article number	Designation	Gas pressure p0	Nitrogen mass
1	0000-236-011	Counter Balance System heavy filled arc.	156 bar	0.359 kg

Export to Excel 

For sea or air freight, the following UN number shall apply:

## UN 3164 Articles, pressurized, hydraulic (with non-flammable, non-toxic gases)

<b>UN number</b>	UN 3164
<b>Proper shipping name</b>	Articles, pressurized, hydraulic (with non-flammable, non-toxic gases)
<b>Class</b>	2.2
<b>Explanation of class</b>	Non-flammable, non-toxic gases
<b>Example</b>	Filled hydropneumatic CBSs
<b>Hazard</b>	<ul style="list-style-type: none"> <li>• Bursting of the pressure vessels (100 - 160 bar)</li> <li>• Splintering not possible</li> <li>• Freezing due to sudden escape of gas</li> </ul>
<b>Measures</b>	<ul style="list-style-type: none"> <li>• Do not loiter in low-lying areas</li> <li>• If possible, drain oil and depressurize CBS</li> </ul>



# 关税信息

统计货号	84795000
原产地	DE
制造商	KUKA ROBOTER
重量	1103 kg

- > **KR 240 R3200 PA arctic** 带有如下的工具 (22)
- > **KR 240 R3200 PA arctic** 有以下选项 (38)
- > **KR 240 R3200 PA arctic** 带有如下的标准组件 (3)
- > **KR 240 R3200 PA arctic** 包含以下危险品 (1)
- > **KR 240 R3200 PA arctic** 需要 (13)
- > **KR 240 R3200 PA arctic** 带有如下的备件 (12)